

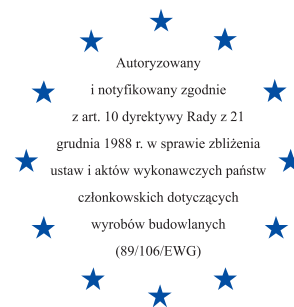

Instytut Techniki Budowlanej

Member of EOTA



European Technical Approval

ETA-13/0452

AR6-W CS 5,5/6,3xL and AR12-W CS 5,5/6,3xL

Fastening screws for sandwich panels

Wkręty do mocowania płyt warstwowych



Europejska Organizacja ds. Aprobat Technicznych
European Organisation for Technical Approvals

Europejska aprobatą techniczną została opracowana
w Zakładzie Aprobát Technicznych
przez mgr inż. Annę KUKULSKĄ-GRABOWSKĄ

Projekt okładki: Ewa Kossakowska

GW II

Kopiowanie aprobaty technicznej
jest dozwolone jedynie w całości

Wykonano z oryginałów bez opracowania wydawniczego

© Copyright by Instytut Techniki Budowlanej
Warszawa 2013

ISBN 978-83-249-7014-8



Instytut Techniki Budowlanej

Dział Upowszechniania Wiedzy

02-656 Warszawa, ul. Ksawerów 21, tel.: 22 843 35 19

Format: pdf Wydano w listopadzie 2013 r. Zam. 654/2013

INSTYTUT TECHNIKI BUDOWLANEJ
PL 00-611 WARSZAWA
ul. FILTROWA 1
tel.: (48 22) 825-04-71;
(48 22) 825-76-55;
fax: (48 22) 825-52-86;
www.itb.pl



Członek EOTA

European Technical Approval

ETA-13/0452

English language translation - the original version is in Polish language

Nazwa handlowa

Trade name

AR6-W CS 5,5/6,3xL i AR12-W CS 5,5/6,3xL

AR6-W CS 5,5/6,3xL and AR12-W CS 5,5/6,3xL

Właściciel aprobaty

Holder of approval

Info-GLOBAL sp. j.

ul. Długa 67

PL 63-400 Ostrów Wielkopolski

Poland

Rodzaj i przeznaczenie wyrobu

*Generic type and use
of construction products*

Wkręty do mocowania płyt warstwowych

Fastening screws for sandwich panels

Termin ważności

Valid

od

from

03. 06. 2013

do

to

03. 06. 2018

Zakład produkcyjny

Manufacturing plant

Info-GLOBAL sp. j.

ul. Długa 67

PL 63-400 Ostrów Wielkopolski

Poland

Niniejsza Europejska

Aprobata Techniczna zawiera

*This European Technical
Approval contains*

13 stron, w tym 5 Załączników

13 pages including 5 Annexes



Europejska Organizacja ds. Aprobatach Technicznych

European Organisation for Technical Approvals

I LEGAL BASES AND GENERAL CONDITIONS

1. This European Technical Approval is issued by Instytut Techniki Budowlanej in accordance with:
 - Council Directive 89/106/EEC of 21 December 1988 on the approximation of laws, regulations and administrative provisions of Member States relating to construction products¹, modified by Council Directive 93/68/EEC of July 1993² and Regulation (EC) № 1882/2003 of the European Parliament and of the Council³;
 - ustawa z dnia 16 kwietnia 2004 r. o wyrobach budowlanych (law on construction products from 16th April 2004)⁴;
 - rozporządzenie Ministra Infrastruktury z dnia 14 października 2004 r. w sprawie europejskich aprobat technicznych oraz polskich jednostek organizacyjnych upoważnionych do ich wydawania (regulation of Ministry of Infrastructure of 14th October 2004 on the European Technical Approvals and Polish bodies entitled to issue them)⁵;
 - Common Procedural Rules for Requesting, Preparing and the Granting of European Technical Approvals set out in the Annex of Commission Decision 94/23/EC⁶.
2. Instytut Techniki Budowlanej is authorized to check whether the provisions of this European Technical Approval are met. Checking may take place in the manufacturing plant. Nevertheless, the responsibility for the conformity of the products to the European Technical Approval and for their fitness for the intended use remains with the holder of the European Technical Approval.
3. This European Technical Approval is not to be transferred to manufacturers or agents of manufacturers other than those indicated on page 1, or manufacturing plants other than those indicated on page 1 of this European Technical Approval.
4. This European Technical Approval may be withdrawn by Instytut Techniki Budowlanej, in particular after information by the Commission on the basis of Article 5 (1) of Council Directive 89/106/EEC.
5. Reproduction of this European Technical Approval including transmission by electronic means shall be in full. However, partial reproduction can be made with the written consent of Instytut Techniki Budowlanej. In this case partial reproduction has to be designated as such. Texts and drawings of advertising brochures shall not contradict or misuse the European Technical Approval.
6. The European Technical Approval is issued by the approval body in its official language. This version corresponds to the version circulated within EOTA. Translations into other languages have to be designated as such.

¹ Official Journal of the European Communities № L 40, 11.02.1989, p. 12

² Official Journal of the European Communities № L 220, 30.08.1993, p. 1

³ Official Journal of the European Union L 284, 31 October 2003, p. 25

⁴ Official Journal of Polish Republic № 92/2004, pos. 881

⁵ Official Journal of Polish Republic № 237/2004, pos. 2375

⁶ Official Journal of the European Communities № L 17, 20.01.1994, p. 34

II SPECIFIC CONDITIONS OF THE EUROPEAN TECHNICAL APPROVAL

1 Definition of the product and intended use

1.1 Definition of the construction product

The fastening screws for sandwich panels AR6-W CS 5,5/6,3xL and AR12-W CS 5,5/6,3xL are a self-drilling screws listed in Table 1. The fastening screws are made of galvanized carbon steel or galvanized carbon steel additionally protected by ceramic coating. Screws are supplied with a metallic washer and an EPDM sealing ring.

The fastening screw for sandwich panels and the corresponding connections are subject to tension and shear forces.

Table 1

No.	Screw	Description	Annex
1	AR6-W CS 5,5/6,3xL	self-drilling screw with hexagon head and sealing washer Ø16 mm	Annex 2
2	AR6-W CS 5,5/6,3xL	self-drilling screw with hexagon head and sealing washer Ø19 mm	Annex 3
3	AR12-W CS 5,5/6,3xL	self-drilling screw with hexagon head and sealing washer Ø16 mm	Annex 4
4	AR12-W CS 5,5/6,3xL	self-drilling screw with hexagon head and sealing washer Ø19 mm	Annex 5

1.2 Intended use

The fastening screw for sandwich panels are intended to be used for fastening of flat, lightly profiled or profiled sandwich panels to metal supporting structures. The core material of sandwich panels shall be made of polystyrene (PS), polyurethane rigid foam (PUR) or mineral wool (MW) with a minimum compression resistance of the core material of 0,04 N/mm² (according to the specifications to the sandwich panels). The sandwich panels can either be used as wall or roof cladding.

The component to be fastened is component I and the supporting structure is component II.

The intended use comprises fastening screws for sandwich panels and connections for indoor and outdoor applications. The fastening screws for sandwich panels which are made of stainless steel are intended to be used in external environments with high corrosion category.

The intended use comprises connections with predominantly static loads (e.g. wind loads, dead loads).

The provisions made in this European Technical Approval are based on an assumed working life of the fastening screws for sandwich panels of 25 years when installed in the works or 50 years if the fastening screws are not accessible after installation and they are sufficient protected against corrosion (e.g. made of stainless steel). The indications given on the working life cannot be interpreted as a guarantee given by the producer or approval body, but are to be regarded only as a means for choosing the right products in relation to the expected economically reasonable working life of the works.

2 Characteristics of product and methods of verification

2.1 Characteristics of product

The fastening screws for sandwich panels shall correspond to the drawings given in the Annexes 2 to 5.

The characteristic material values, dimensions and tolerances of the fastening screw not indicated in the Annexes shall correspond to the respective values laid down in the technical documentation⁷ to this European Technical Approval.

The characteristic values of shear and tension resistance of the connections made with the fastening screws for sandwich panels as well as the maximum head displacement are given in the appropriate Annexes or in clause 4.2.

The fastening screws for sandwich panels are considered to satisfy the requirements of performance class A1 of reaction to fire.

2.2 Methods of verification

The assessment of the fitness of the fastening screws for sandwich panels for the intended use in relation to the Essential Requirements ER 1 (Mechanical resistance and stability), ER 2 (Safety in case of fire), ER 4 (Safety in use) and additional aspects of durability has been made in accordance with section 3.2 of the Common Procedural Rules for Requesting, Preparing and the Granting of European technical approvals set out in the Annex to Commission Decision 94/23/EC⁶.

The assessment of the resistance to fire performance is only relevant to the assembled system (fastening screws for sandwich panels, sandwich panels, supporting structure) which is not part of the ETA.

The fastening screws for sandwich panels are considered to satisfy the requirements of performance class A1 of reaction to fire, in accordance with the provisions of the EC Decision 96/603/EC (as amended) without the need for testing on the basis of its listing in that decision.

Concerning Essential Requirements No. 1 (Mechanical resistance and stability) and No. 4 (Safety in use) the following applies:

- the characteristic values of resistance given in Annexes were determined by shear and tension tests and the values for the maximum head displacement were determined by bending test,
- the formulas to calculate the design resistance are given in clause 4.2.1.

3 Evaluation and attestation of conformity and CE-marking

3.1 Attestation of conformity system

According to the Decision 1998/214/EC of the European Commission⁸ system 2+ of the attestation of conformity applies.

This system of attestation of conformity provides declaration of conformity of the

⁷ The technical documentation to this European technical approval is deposited at Instytut Techniki Budowlanej and, as far as relevant for the tasks of the approved bodies involved in the attestation of conformity procedure is handed over to the approved bodies.

⁸ Official Journal of the European Communities № L 80 of 18.03.1998.

product by the manufacturer on the basis of:

(a) Tasks for the manufacturer:

- (1) initial type-testing of the product;
- (2) factory production control;
- (3) testing of the samples taken at the factory in accordance with a prescribed test plan.

(b) Tasks for the approved body:

- (4) certification of factory production control on the basis of:
 - initial inspection of factory and of factory production control;
 - continuous surveillance, assessment and approval of factory production control.

3.2 Responsibilities

3.2.1 Tasks for the manufacturer

3.2.1.1 Factory production control

The manufacturer shall exercise permanent internal control of production. All the elements, requirements and provisions adopted by the manufacturer shall be documented in a systematic manner in the form of written policies and procedures, including records of results performed. This production control system shall ensure that the products are in conformity with this European Technical Approval.

The manufacturer shall only use raw materials stated in the technical documentation of this ETA.

The factory production control shall be in accordance with the control plan⁹ which is a part of the technical documentation of this ETA. The control plan has been agreed between the manufacturer and Instytut Techniki Budowlanej and is laid down in the context of the factory production control system operated by the manufacturer and deposited with Instytut Techniki Budowlanej.

The results of factory production control shall be recorded and evaluated in accordance with the provisions of the control plan.

3.2.1.2 Other tasks for the manufacturer

The manufacturer shall, on the basis of a contract, involve a body which is notified for the task referred to in section 3.1 in the field of prefabricated structural components made of hot-rolled steel products in order to undertake the actions laid down in section 3.2.2. For this purpose, the control plan referred to in section 3.2.1.1 and 3.2.2 shall be handed over by the manufacturer to the notified body involved.

The manufacturer shall make a declaration of conformity, stating that the fastening screws for sandwich panels are in conformity with the provisions of this ETA.

3.2.2 Tasks for the notified body

The notified body shall perform the:

- initial inspection of factory and of factory production control,

⁹ The control plan has been deposited with Instytut Techniki Budowlanej and may be handed over only to the notified body involved in the procedure of attestation of conformity.

- continuous surveillance, assessment and approval of factory production control, in accordance with the provisions laid down in the control plan.

The notified body shall retain the essential points of its actions referred to above and state the results obtained and conclusion drawn in written report.

The notified certification body involved by the manufacturer shall issue an EC certificate of conformity of the factory production control stating the conformity with provisions of this ETA.

In cases where the provisions of the ETA and its control plan are no longer fulfilled the notified certification body shall withdraw the certificate of conformity and inform Instytut Techniki Budowlanej without delay.

3.3 CE marking

The CE marking shall be affixed on the product itself, the attached label, or the accompanying commercial documents. The letters „CE” shall be followed by the following additional information:

- the name or identification mark of the producer and address of the producer (legal entity responsible for the manufacture),
- the last two digits of the year in which the CE-marking was affixed,
- the number of the EC certificate for the factory production control,
- the number of the European Technical Approval,
- the name of the product.

4 Assumptions under which the fitness of the product for the intended use was favorably assessed

4.1 Manufacturing

The fastening screws for sandwich panels are manufactured in accordance with the provisions of the ETA using the manufacturing process as laid down in the technical documentation.

The ETA is issued on the basis of agreed data/information, deposited with Instytut Techniki Budowlanej, which identifies the product that has been assessed and judged. Changes to the product or production process, which could result in this deposited data/information being incorrect, should be notified to Instytut Techniki Budowlanej before the changes are introduced. Instytut Techniki Budowlanej will decide whether or not such changes affect the ETA and consequently the validity of the CE marking on the basis of the ETA and if so whether further assessment or alterations to the ETA shall be necessary.

4.2 Design

4.2.1 General

Fastening screw for sandwich panels completely or partly exposed to external weather or similar conditions are made of stainless steel or are protected against corrosion. For the corrosion protection the rules given in EN 1090-2:2008+A1:2011, EN 1993-1-3:2006+AC:2009 and EN 1993-1-4:2006 are taken into account.

In the following and in the Annexes the component to be fastened is component I

and the supporting structure is component II. Furthermore the following symbols are used, see also Annex 1:

d or D	thickness of the sandwich panel
t_{N1}	thickness of the outer face / top plate (on the side of the screw head)
t_{N2}	thickness of the inner face / bottom plate (on the side of the supporting structure)
t_{II}	thickness of the supporting structure
u	from screw axes measured screw head displacement, resulting from the displacement of the outer face of the sandwich panels by thermal expansion e.g. caused by solar radiation
max u	maximum allowed screw head displacement; $u < \max u$

For calculation of shear resistance of the connection the value for the plate thickness t_{N2} (plate in contact with the supporting structure) is used as relevant. For calculation of tension resistance of the connection and pull-over the relevant thickness is plate thickness t_{N1} (plate in contact with screw head).

The load is predominantly static (e.g. wind loads are regarded as predominantly static).

Dimensions, material properties, minimum effective screw-in length l_{ef} , nominal material thicknesses t_{N1} and t_{N2} and maximum head displacement as stated in the ETA are observed.

The verification concept stated in EN 1990:2002+A1:2005/AC:2010 is used for the design of the connections made with the fastening screw for sandwich panels. The characteristic values of shear and tension resistance, stated in the Annexes are to be used for the design of the entire connections.

For intermediate thickness of component I or component II the characteristic value for the thinner component is taken.

The following formulas are to be used to calculate the values of design resistance:

$$N_{R,d} = \frac{N_{R,k}}{\gamma_M}$$

$$V_{R,d} = \frac{V_{R,k}}{\gamma_M}$$

The recommended partial safety factor $\gamma_M = 1,33$ is used in order to determine the corresponding design resistances, provided no values are given in national regulations of the member state in which the fastening screws are used or in the respective national Annex to Eurocode 3.

In case of combined tension and shear forces the linear interaction formula according to EN 1993-1-3:2006+AC:2009, section 8.3 (8) is taken into account.

$$\frac{N_{S,d}}{N_{R,d}} + \frac{V_{S,d}}{V_{R,d}} \leq 1,0$$

The possibly required reduction of the tension resistance to 70% of the characteristic values of tension resistance given in the Annexes is to be taken into account for connections of sandwich panels to thin-walled (plate thickness $t < 5$ mm) asymmetric profiles like Z- or C- shaped profiles.

4.3 Installation

The fitness for use of the fastening screw for sandwich panels can only be assumed if the following conditions of installation are met:

- the installation is to be only carried out according to the manufacturer's instructions; manufacturer hands over the assembly instructions to the assembler,
- it is guaranteed by the execution that no bimetallic corrosion will occur,
- screws with washers and EPDM sealing rings exposed to external weather are screwed-in with electric driver with appropriate set depth stop,
- the use of impact wrenches is not allowed,
- the fastening screws are fixed rectangular to the surface of the components to guarantee a correct load bearing and if necessary rain-proof connection,
- component I and component II are in contact to each other in the connection area; the use of compression resistant thermal insulation strips up to the thickness of 3 mm is allowed,
- fastening screws are screwed-in with the cylindrical part of the thread: through the material if component II has a thickness up to 6 mm and at least 6 mm if component II has a thickness over 6 mm,
- welded drill bits or hardened tips are therefore not been taken into account,
- the manufacturer information about the maximum clamp length is considered,
- already loaded screws in regular load bearing connections are if required only replaced by thread forming screws with a larger diameter, therefore the hole has to be predrilled for the thicker fastening screw,
- the conformity of the installed fastening screws with the provisions of the ETA is attested by the executing company.

5 Recommendations for the manufacturer

It is in the responsibility of the manufacturer to ensure that the information on the specific conditions according to 1, 2, 4.2 and 4.3 (and in Annexes) is given to those who are concerned. This information may be given by reproduction of the respective parts of the European Technical Approval. In addition all installation data (torque moment, application limits) shall be shown clearly on the package and/or on an enclosed instruction sheet, preferably using illustration(s).

On behalf of Instytut Techniki Budowlanej



Jan Bobrowicz
Director of ITB

Example of execution of a connection

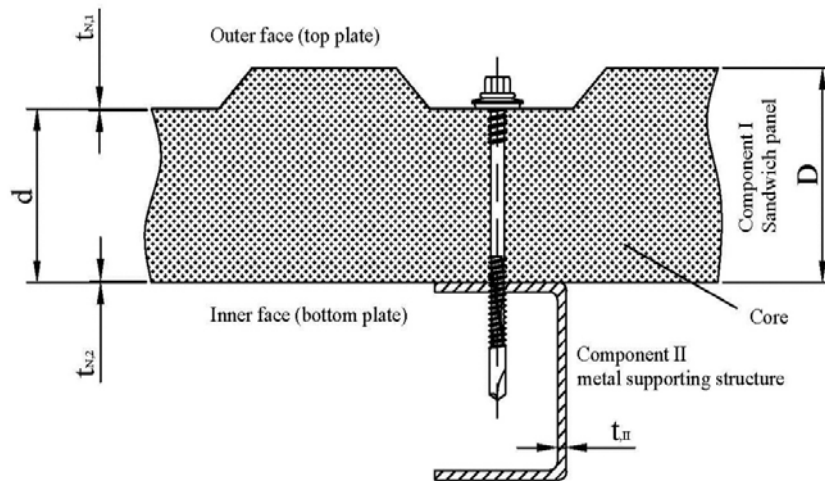

Loading conditions

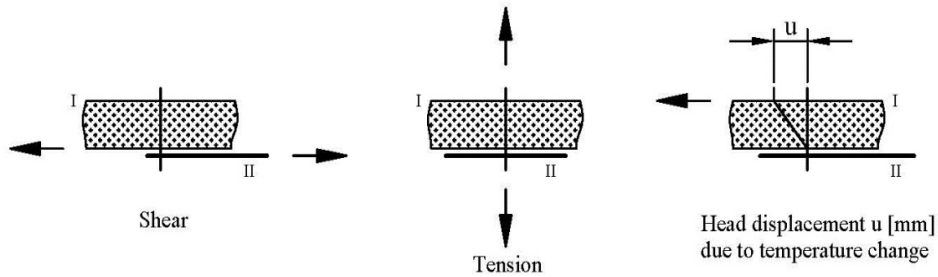

**Fastening screws for sandwich panels
 AR6-W CS 5,5/6,3xL and AR12-W CS 5,5/6,3xL**

Example of execution of a connection. Loading conditions

Annex 1
 of European
 Technical Approval
 ETA-13/0452

<p><u>Materials</u></p> <p>Fastener: carbon steel – SAE 1022, quenched, tempered and galvanized (12 µm) or galvanized with additional ceramic coating</p> <p>Washer: metallic washer made of carbon steel or stainless steel with EPDM sealing ring</p> <p>Component I: S280GD, S320GD or S350GD – EN 10346</p> <p>Component II: S235 – EN 10025-1 S280GD, S320GD or S350GD – EN 10346</p>	
Drilling capacity: $\Sigma(t_{N2} + t_{II}) \leq 6 \text{ mm}$	
<u>Timber substructures</u> no performance determined	

Component II: t_{II} in [mm]		1,50	2,00	2,50	3,00	4,00	5,00	6,00	8,00	$\geq 10,00$	
Component I: t_{N1} or t_{N2} in [mm]	V _{R,k} in [kN]	0,40	0,86	0,86	0,86	0,86	0,86	0,86	—	—	—
		0,50	1,51	1,51	1,51	1,51	1,51	1,51	—	—	—
		0,55	1,51	1,51	1,51	1,51	1,51	1,51	—	—	—
		0,63	1,68	1,68	1,68	1,68	1,68	1,68	—	—	—
		0,75	1,68	1,68	1,68	1,68	1,68	1,68	—	—	—
		0,88	1,68	1,68	1,68	1,68	1,68	1,68	—	—	—
		1,00	1,68	1,68	1,68	1,68	1,68	1,68	—	—	—
	N _{R,k} in [kN]	0,40	1,23	1,23	1,23	1,23	1,67	1,67	—	—	—
		0,50	1,23	1,23	1,23	1,23	2,81	2,81	—	—	—
		0,55	1,23	1,23	1,23	1,23	2,81	2,81	—	—	—
		0,63	1,23	1,23	1,23	1,23	3,53	3,53	—	—	—
		0,75	1,23	1,23	1,23	1,23	4,34	4,34	—	—	—
		0,88	1,23	1,23	1,23	1,23	4,34	4,34	—	—	—
		1,00	1,23	1,23	1,23	1,23	4,34	4,34	—	—	—
max. head displacement u depending on the sandwich panel thickness in [mm]	30	10	10	10	0,7	0,7	0,7	—	—	—	
	40	10	10	10	0,7	0,7	0,7	—	—	—	
	50	10	10	10	0,7	0,7	0,7	—	—	—	
	60	10	10	10	2	2	2	—	—	—	
	70	10	10	10	2	2	2	—	—	—	
	80	10	10	10	2	2	2	—	—	—	
	90	10	10	10	10	3	3	—	—	—	
	100	10	10	10	10	3	3	—	—	—	
	120	10	10	10	10	3	3	—	—	—	
	≥ 140	10	10	10	10	3	3	—	—	—	

<p>Fastening screws for sandwich panels AR6-W CS 5,5/6,3xL and AR12-W CS 5,5/6,3xL</p>	<p>Annex 2 of European Technical Approval ETA-13/0452</p>
<p>Self-drilling screw AR6-W CS 5,5/6,3 x L with hexagon head and sealing washer $\phi 16 \text{ mm}$</p>	

<p>Materials</p> <p>Fastener: carbon steel – SAE 1022, quenched, tempered and galvanized (12 µm) or galvanized with additional ceramic coating</p> <p>Washer: metallic washer made of carbon steel or stainless steel with EPDM sealing ring</p> <p>Component I: S280GD, S320GD or S350GD – EN 10346</p> <p>Component II: S235 – EN 10025-1 S280GD, S320GD or S350GD – EN 10346</p>	
Drilling capacity: $\Sigma(t_{N2} + t_{II}) \leq 6 \text{ mm}$	
Timber substructures no performance determined	

Component II: t_{II} in [mm]		1,50	2,00	2,50	3,00	4,00	5,00	6,00	8,00	$\geq 10,00$	
Component I: t_{N1} or t_{N2} in [mm]	V _{R,k} in [kN]	0,40	0,86	0,86	0,86	0,86	0,86	0,86	—	—	—
		0,50	1,51	1,51	1,51	1,51	1,51	1,51	—	—	—
		0,55	1,51	1,51	1,51	1,51	1,51	1,51	—	—	—
		0,63	1,68	1,68	1,68	1,68	1,68	1,68	—	—	—
		0,75	1,68	1,68	1,68	1,68	1,68	1,68	—	—	—
		0,88	1,68	1,68	1,68	1,68	1,68	1,68	—	—	—
		1,00	1,68	1,68	1,68	1,68	1,68	1,68	—	—	—
	N _{R,k} in [kN]	0,40	1,23	1,23	1,23	1,23	1,91	1,91	—	—	—
		0,50	1,23	1,23	1,23	1,23	3,27	3,27	—	—	—
		0,55	1,23	1,23	1,23	1,23	3,27	3,27	—	—	—
		0,63	1,23	1,23	1,23	1,23	4,13	4,13	—	—	—
		0,75	1,23	1,23	1,23	1,23	4,77	4,77	—	—	—
		0,88	1,23	1,23	1,23	1,23	4,77	4,77	—	—	—
		1,00	1,23	1,23	1,23	1,23	4,77	4,77	—	—	—
max. head displacement u depending on the sandwich panel thickness in [mm]	30	10	10	10	0,7	0,7	0,7	—	—	—	
	40	10	10	10	0,7	0,7	0,7	—	—	—	
	50	10	10	10	0,7	0,7	0,7	—	—	—	
	60	10	10	10	2	2	2	—	—	—	
	70	10	10	10	2	2	2	—	—	—	
	80	10	10	10	2	2	2	—	—	—	
	90	10	10	10	10	3	3	—	—	—	
	100	10	10	10	10	3	3	—	—	—	
	120	10	10	10	10	3	3	—	—	—	
	≥ 140	10	10	10	10	3	3	—	—	—	

<p>Fastening screws for sandwich panels AR6-W CS 5,5/6,3xL and AR12-W CS 5,5/6,3xL</p>	<p>Annex 3</p> <p>of European Technical Approval ETA-13/0452</p>
<p>Self-drilling screw AR6-W CS 5,5/6,3 x L with hexagon head and sealing washer $\phi 19 \text{ mm}$</p>	

<p>Materials</p> <p>Fastener: carbon steel – SAE 1022, quenched, tempered and galvanized (12 µm) or galvanized with additional ceramic coating</p> <p>Washer: metallic washer made of carbon steel or stainless steel with EPDM sealing ring</p> <p>Component I: S280GD, S320GD or S350GD – EN 10346</p> <p>Component II: S235 – EN 10025-1 S280GD, S320GD or S350GD – EN 10346</p>	
Drilling capacity: $\Sigma(t_{N2} + t_{t1}) \leq 12$ mm	
<p>Timber substructures</p> <p>no performance determined</p>	

Component II: t_{ii} in [mm]		3,00	4,00	5,00	6,00	8,00	10,00	11,00	12,00	14,00	
Component I: $t_{k,1}$ or $t_{k,2}$ in [mm]	V _{R,k} in [kN]	0,40	0,88	0,88	0,88	0,88	0,88	0,88	0,88	—	—
		0,50	1,50	1,50	1,50	1,50	1,50	1,50	1,50	—	—
		0,55	1,50	1,50	1,50	1,50	1,50	1,50	1,50	—	—
		0,63	1,71	1,71	1,71	1,71	1,71	1,71	1,71	—	—
		0,75	1,71	1,71	1,71	1,71	1,71	1,71	1,71	—	—
		0,88	1,71	1,71	1,71	1,71	1,71	1,71	1,71	—	—
		1,00	1,71	1,71	1,71	1,71	1,71	1,71	1,71	—	—
	N _{R,k} in [kN]	0,40	1,67	1,67	1,67	1,67	1,67	1,67	1,67	—	—
		0,50	2,81	2,81	2,81	2,81	2,81	2,81	2,81	—	—
		0,55	2,81	2,81	2,81	2,81	2,81	2,81	2,81	—	—
		0,63	2,53	2,53	2,53	2,53	2,53	2,53	2,53	—	—
		0,75	4,34	4,34	4,34	4,34	4,34	4,34	4,34	—	—
		0,88	4,34	4,34	4,34	4,34	4,34	4,34	4,34	—	—
		1,00	4,34	4,34	4,34	4,34	4,34	4,34	4,34	—	—
max. head displacement u depending on the sandwich panel thickness in [mm]	30	0,7	0,7	0,7	0,7	0,7	0,7	0,7	—	—	
	40	0,7	0,7	0,7	0,7	0,7	0,7	0,7	—	—	
	50	0,7	0,7	0,7	0,7	0,7	0,7	0,7	—	—	
	60	2	2	2	2	2	2	2	—	—	
	70	2	2	2	2	2	2	2	—	—	
	80	2	2	2	2	2	2	2	—	—	
	90	3	3	3	3	3	3	3	—	—	
	100	3	3	3	3	3	3	3	—	—	
	120	3	3	3	3	3	3	3	—	—	
	≥ 140	3	3	3	3	3	3	3	—	—	

<p>Fastening screws for sandwich panels AR6-W CS 5,5/6,3xL and AR12-W CS 5,5/6,3xL</p>	<p>Annex 4</p> <p>of European Technical Approval ETA-13/0452</p>
<p>Self-drilling screw AR12-W CS 5,5/6,3 x L with hexagon head and sealing washer $\phi 16$ mm</p>	

<p>Materials</p> <p>Fastener: carbon steel – SAE 1022, quenched, tempered and galvanized (12 µm) or galvanized with additional ceramic coating</p> <p>Washer: metallic washer made of carbon steel or stainless steel with EPDM sealing ring</p> <p>Component I: S280GD, S320GD or S350GD – EN 10346</p> <p>Component II: S235 – EN 10025-1 S280GD, S320GD or S350GD – EN 10346</p>	
<p>Drilling capacity: $\Sigma(t_{N2} + t_{II}) \leq 12 \text{ mm}$</p>	
<p>Timber substructures no performance determined</p>	

Component II: t_{II} in [mm]		3,00	4,00	5,00	6,00	8,00	10,00	11,00	12,00	14,00	
Component I: t_{N1} or t_{N2} in [mm]	V _{R,k} in [kN]	0,40	0,88	0,88	0,88	0,88	0,88	0,88	0,88	—	—
		0,50	1,50	1,50	1,50	1,50	1,50	1,50	1,50	—	—
		0,55	1,50	1,50	1,50	1,50	1,50	1,50	1,50	—	—
		0,63	1,71	1,71	1,71	1,71	1,71	1,71	1,71	—	—
		0,75	1,71	1,71	1,71	1,71	1,71	1,71	1,71	—	—
		0,88	1,71	1,71	1,71	1,71	1,71	1,71	1,71	—	—
		1,00	1,71	1,71	1,71	1,71	1,71	1,71	1,71	—	—
	N _{R,k} in [kN]	0,40	1,91	1,91	1,91	1,91	1,91	1,91	1,91	—	—
		0,50	3,27	3,27	3,27	3,27	3,27	3,27	3,27	—	—
		0,55	3,27	3,27	3,27	3,27	3,27	3,27	3,27	—	—
		0,63	4,13	4,13	4,13	4,13	4,13	4,13	4,13	—	—
		0,75	4,77	4,77	4,77	4,77	4,77	4,77	4,77	—	—
		0,88	4,77	4,77	4,77	4,77	4,77	4,77	4,77	—	—
		1,00	4,77	4,77	4,77	4,77	4,77	4,77	4,77	—	—
max. head displacement u depending on the sandwich panel thickness in [mm]	30	0,7	0,7	0,7	0,7	0,7	0,7	0,7	—	—	
	40	0,7	0,7	0,7	0,7	0,7	0,7	0,7	—	—	
	50	0,7	0,7	0,7	0,7	0,7	0,7	0,7	—	—	
	60	2	2	2	2	2	2	2	—	—	
	70	2	2	2	2	2	2	2	—	—	
	80	2	2	2	2	2	2	2	—	—	
	90	3	3	3	3	3	3	3	—	—	
	100	3	3	3	3	3	3	3	—	—	
	120	3	3	3	3	3	3	3	—	—	
	≥ 140	3	3	3	3	3	3	3	—	—	

<p>Fastening screws for sandwich panels AR6-W CS 5,5/6,3xL and AR12-W CS 5,5/6,3xL</p>	<p>Annex 5 of European Technical Approval ETA-13/0452</p>
<p>Self-drilling screw AR12-W CS 5,5/6,3 x L with hexagon head and sealing washer ø19 mm</p>	



Instytut Techniki Budowlanej

ISBN 978-83-249-7014-8